

**2-year
Warranty**

forza[®]
POWER TECHNOLOGIES



User Manual

Uninterruptible Power Supply System

FDC-106K / FDC-110K

Table of content

1. Introduction
 - 1.1 Transportation and storage
 - 1.2 Preliminary steps
 - 1.3 Initial setup
 - 1.4 Important safety instructions
 - 1.5 Standards
2. Installation and operation
 - 2.1 Unpacking and inspection
 - 2.2 UPS front and rear panel views
 - 2.3 Single UPS installation
 - 2.4 Output configuration
 - 2.5 ForzaTracker monitoring software
3. Advanced operation
 - 3.1 Description of buttons and functions
 - 3.2 LED indicators and LCD panel
 - 3.3 Audible alarm
 - 3.4 Single UPS operation
 - 3.5 Parallel operation
 - 3.6 Abbreviations in the LCD display
 - 3.7 UPS parameter settings
 - 3.8 Operating mode/Status description
 - 3.9 Fault codes
 - 3.10 Warning indicators
4. Troubleshooting guide
5. Storage and maintenance
6. Technical specifications

1. Introduction

Thank you for purchasing the Forza Atlas **FDC 106K/110K** Online UPS. To enjoy all the features and benefits of this unit, please read and follow all installation and operation instructions thoroughly before unpacking, installing or operating this device. After you have read this manual, keep it in a safe place for future reference.

The information contained in this manual covers the 6000VA and 10000VA uninterruptible power systems, their basic functions, operating procedures, options available and troubleshooting guide. It also includes information on how to ship, store, handle, and install the equipment.

1-1. Transportation and storage

- Transport the UPS system only in the original package to protect it against shock and impact.
- The UPS must be stored in a dry, well-ventilated area.

1-2. Preliminary steps

- Water condensation may occur if the UPS is unpacked in a very cold environment and then moved to a warmer location.
- The UPS must be thoroughly dry before being installed. Failure to do so may increase the risk of electric shock.
- Do not install the UPS system near water or in moist environments.
- To reduce the risk of overheating, do not cover the cooling vents in the UPS housing.
- Avoid exposing the UPS to direct sunlight or installing the unit near heat-emitting appliances, such as electric heaters or furnaces.

1-3. Initial setup

- Do not connect appliances or equipment that may overload the UPS system (such as big motor-type equipment) to the UPS output sockets or terminal.
- Place cables in such a way that no one can step on or trip over them.
- Do not block air vents in the housing of UPS. The UPS must be installed in a location with good ventilation. Ensure enough space on each side for ventilation.
- The UPS is provided with an earthed terminal. Equipotential earth bonding to the external UPS battery cabinets must be provided if such configuration is used.
- The UPS can be installed only by qualified maintenance personnel.
- These UPS units are extremely heavy. Caution should be taken in moving and positioning equipment.
- An appropriate disconnect device as short-circuit backup protection should be provided in the building wiring installation.
- An integral single emergency switching device which prevents further supply to the load by the UPS in any mode of operation should be provided in the building wiring installation
- Connect the earth before connecting the unit to the building wiring terminal.
- Installation and wiring must be performed in accordance with local electrical regulations and laws.

1-4. Important safety instructions

- Do not disconnect the earth conductor cable on the UPS or the building wiring terminals at any time since this would cancel the protective earth of the UPS system and of all connected loads.
- In order to provide security and safety measures according to NFPA under 70 NEC article 250.20(D), the Neutral output is internally grounded to the chassis of the UPS as a grounding system.
- The UPS system features its own, internal current source (batteries). The UPS output sockets or output terminals block may be electrically live even if the UPS system is not connected to the building wiring outlet.
- In the event of an emergency, pull the EPO cable if in default mode or press the switch connected to the EPO if that option is installed. Then disconnect the power from the AC mains to properly disable the UPS.
- Do not allow any kind of liquid or foreign object to enter this UPS unit. Do not place beverages or any other containers with liquid on or nearby the unit.
- The UPS can be operated by any individuals with no previous experience.

1-5. Standards

* Safety		
IEC/EN 62040-1		
* EMI		
Conducted emission	IEC/EN 62040-2	Category C3 [□]
Radiated emission	IEC/EN 62040-2	Category C3 [□]
* EMS		
ESD	IEC/EN 61000-4-2	Level 4 [□]
RS	IEC/EN 61000-4-3	Level 3 [□]
EFT	IEC/EN 61000-4-4	Level 4 [□]
SURGE	IEC/EN 61000-4-5	Level 4 [□]
CS	IEC/EN 61000-4-6	Level 3 [□]
Power-frequency magnetic field	IEC/EN 61000-4-8	Level 4 [□]
Low frequency signals	IEC/EN 61000-2-2	
Warning: This product is intended for commercial and industrial applications. Installation in the proper environment is required.		

2. Installation and operation

The Forza Atlas series is offered in two different models, as shown in the table below.

Model	Capacity
FDC-006K	6000 VA (6000 W)
FDC-010K	10000 VA (10000 W)

2-1. Unpacking and inspection

Remove the UPS from its package and make sure that all the following items are included:

- One UPS unit
- One user manual (digital copy in CD)
- One monitoring software CD (ForzaTracker)
- One USB cable
- Warranty certificate

Carefully inspect the UPS to check for any damages that may have occurred during shipping. Should any evidence of damage be found or if some parts are missing, do not turn the UPS on; you must immediately notify the carrier or dealer where you purchased the unit.

2-2. UPS front and rear panel views

Front view



Rear panel diagram

6K/10K

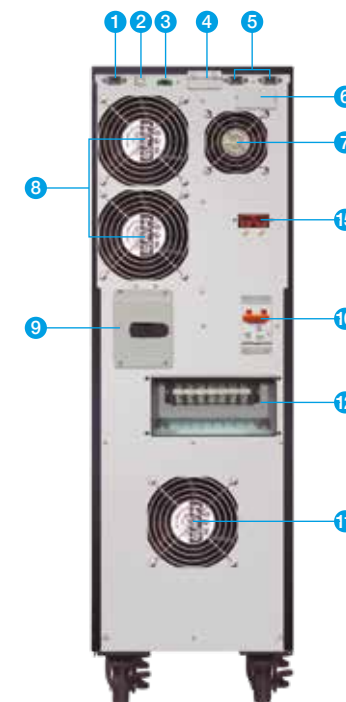

Diagram 1: Rear panel overview

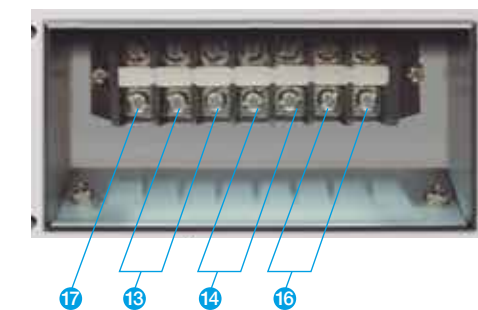

Diagram 2: Input/output terminal

1. RS-232 communication port
2. USB communication port
3. Emergency power off (EPO) connector
4. Parallel current port
5. Parallel data ports
6. Intelligent slot
7. Charger fan
8. Power stage fan
9. Maintenance bypass switch
10. Input circuit breaker
11. Isolation transformer fan
12. Input/output terminal (Refer to diagram 2 for details)
13. Output terminal 1
14. Output terminal 2
15. External battery connector
16. Utility input terminal
17. Non-isolated neutral terminal

2-3. Single UPS installation

Installation and wiring must be performed by qualified personnel, and in accordance with the local electrical regulations and codes. Also, you must observe the following instructions:

- 1) Make sure the mains wire and breakers in the building are enough for the rated capacity of the UPS to avoid the hazards of electric shock or fire.
Note: Do not use a wall receptacle as the input power source for the UPS, as its rated current is less than the UPS maximum input current. Failure to do so may result in a broken or burned out receptacle.
- 2) For safety considerations, turn off the mains switch in the building before installation.
- 3) Turn off all the devices before connecting them to the UPS.
- 4) Wiring sizes should be installed in accordance with the following table:

Model	Wiring specification (AWG)			
	Input	Output	Non-isolated Neutral	Ground
6K	10	10	10	10
10K	8	8	8	8

Note 1: The cable for 6K should be able to withstand currents of over 40A. It is recommended to use a 10AWG or thicker wire for safety and efficiency.

Note 2: The cable for 10K should be able to withstand currents of over 63A. It is recommended to use an 8AWG or thicker wire for safety and efficiency.

Note 3: For single model, it is not necessary to connect the non-isolated neutral terminal.

Note 4: The color selection of wires should be made according to the local electrical codes and regulations.

- 5) Remove the terminal block cover on the rear panel of UPS. Proceed to connect the wires according to the following terminal block diagrams: (Make sure to attach the earth wire first when connecting the wires. When removing the wiring, make sure to remove the earth wire last).

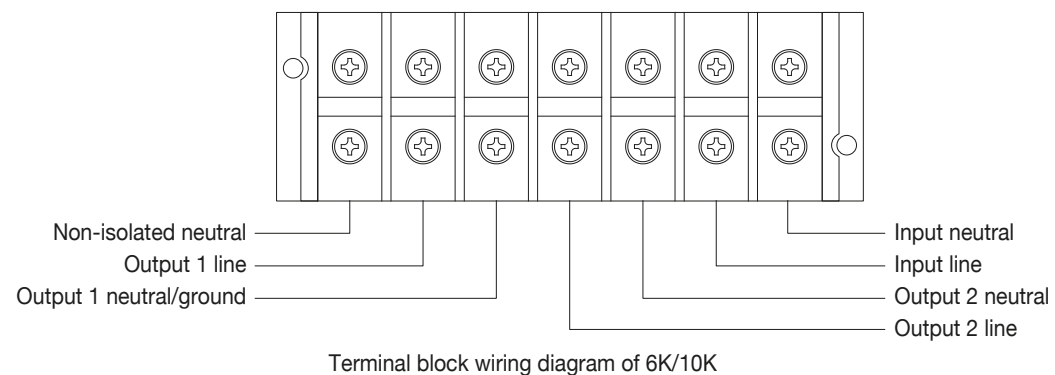

Note 1: Make sure that the input and output wires and the input and output terminals are connected tightly.

Note 2: There are two output terminal configurations to meet customers' diverse requirements for serial or parallel connection. Please refer to section 2.4.

Note 3: Install the leak current protective breaker at the output power distribution panel of the UPS, if necessary.

6) Put the terminal block cover back in the rear panel of the UPS.

Warning:

- For safety considerations, switch all power off using the main switch before installation.
Note: The battery breaker must also be set to OFF before installing the battery pack.
- Pay close attention to the rated battery voltage marked on the rear panel. If you want to change the number of batteries, please make sure you modify the settings accordingly. A connection with the wrong battery voltage may cause permanent damage to the UPS. Make sure the voltage of the battery pack is correct.
- Pay close attention to the polarity markings on the external battery terminal block, and make sure to match the correct battery polarity of the cells. Wrong connection may cause permanent damage to the UPS.
- Make sure the protective earth ground wiring is correctly installed. The wire current specification, color, position, connection and conductance reliability should be checked carefully.
- Make sure the utility input and output wiring is correct. The wire current specification, color, position, connection and conductance reliability should be checked carefully. Make sure the L/N wiring is correct, not reverse and short-circuited.

2-4. Output configuration

Option 1:

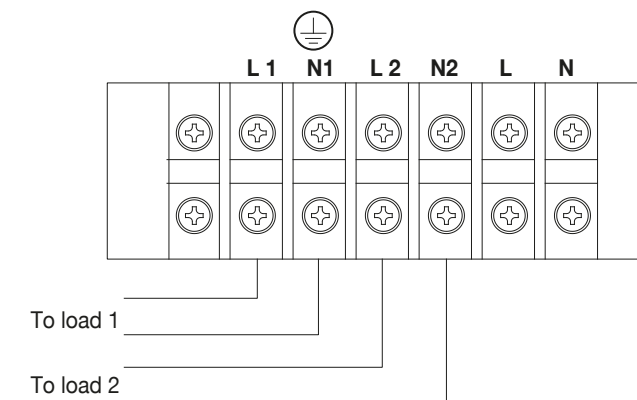

There are 2 sets of low-voltage outputs (104/110/115/120V) on L1-N1 and L2-N2. Each set is able to provide 50% of the UPS rated current. Connect one load to L1-N1 and the other load to L2-N2.

Option 2:

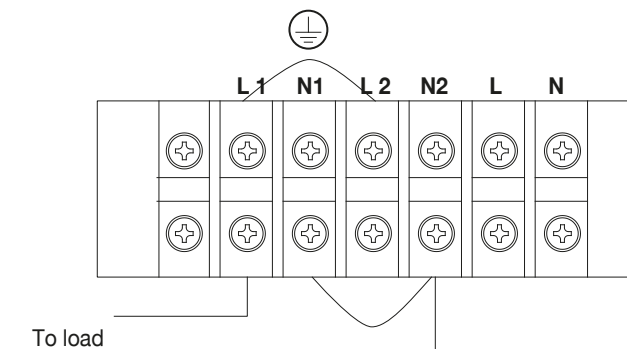

After connecting L1-L2 and N1-N2, it becomes one low-voltage output (104/110/115/120V) at L1-N1 for 100% of the UPS rated current. Connect load to L1-N1 or L2-N2.

Option 3:

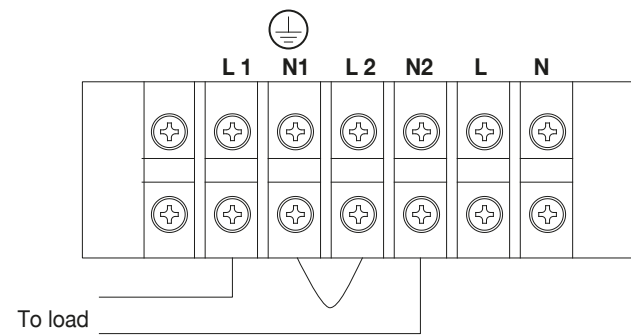

After connecting N1 and L2, it becomes one high-voltage output (208/220/230/240V) at L1-N2 for 100% of the UPS rated current. Connect load to L1-N2.

Option 4:

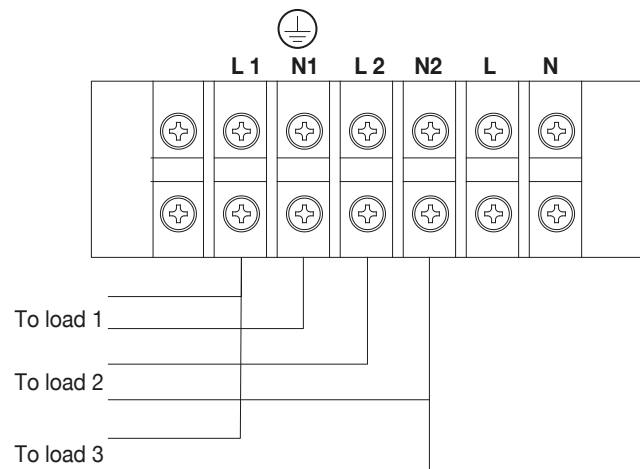

After connecting N1 and L2, it becomes three outputs, one high-voltage output (208/220/230/240V) at L1-N2 and two low-voltage outputs (104/110/115/120V) at L1-N1 and L2-N2. However, there is a limit for current rating at L1-N1 and L2-N2: 25A for 6K model and 42A at 10K model. You must connect the load taking into account such limits. Please read the notes before installation. Connect the low-voltage load to L1-N1 and L2-N2, and connect the high-voltage load to L1-N2.

Note 1: If any load current in L1-N1 or L2-N2 is higher than 25A in 6K model and 42A in 10K model, the UPS will still operate normally without overload warning because the total load is under the specified limit. However, the high current can damage the isolation transformer due to overheat caused by the high current. Hence, the installation must be done with a technician to ensure that the load current will not exceed this limitation.

Note 2: When connecting to low-voltage and high-voltage at the same time as described in option 4, the L1-N1 and L2-N2 will feed low-voltage loads in non-isolated status because high-voltage is being generated by shorting N1-L2. If keeping a connected load in isolated status is required, we recommend that you may only use two low-voltages at L1-N1 or L2-N2 like illustrated in option 1, and also make sure that the total current in L1-N1 or L2-N2 does not exceed the value specified in **Note1**.

2-5. ForzaTracker monitoring software

ForzaTracker is a new generation of UPS monitoring software, which provides user-friendly interface to monitor and control your Uninterruptible Power System. This unique software provides safe auto-shutdown for multi-computer systems during power failures. With this software, users can monitor and control any UPS on the same LAN no matter how far they might be from the UPS.

Installation procedure for Windows users:

1. Use the supplied CD or go to the website: <http://www.forzaups.com/us/driver-downloads/>.
2. After clicking the software icon, choose the required operation system.
3. Follow the on-screen instructions to install the software.
4. When you finished downloading all required files, enter the serial No (Installation Password): **5242-87f6-64re-di8d-986u to install the software (include the hyphe**ns).

5. In order to access as Administrator, input the password: 111296.

6. When your computer restarts, the management software will appear as a light blue round icon located in the system tray, near the clock.

For Mac users, please refer to the ForzaTracker quick installation guide inside the Mac folder.

3. Advanced operation

3-1. Description of buttons and functions

Button	Function
ON/Enter Button	<ul style="list-style-type: none"> • Turns on the UPS: Press and hold this button over 0.5 second to turn on the UPS. • Enter Key: Press this button to confirm the selected settings of the configuration menu.
OFF/ESC Button	<ul style="list-style-type: none"> • Turns off the UPS: Press and hold this button for 0.5 second to turn off the UPS. • Esc key: Press this button to return to the last setting of the configuration menu.
Test/Up Button	<ul style="list-style-type: none"> • Battery test: Press and hold this button for 0.5 second to test the battery status while in AC mode, or CVCF mode. • UP key: Press this button to display the next selection in the configuration menu.
Mute/Down Button	<ul style="list-style-type: none"> • Mutes the alarm: Press and hold the button for 0.5 second to mute the buzzer. Please refer to sections below for details. • Down key: Press this button to display previous selection in the configuration menu.
Test/Up + Mute/Down Button	<ul style="list-style-type: none"> • Press and hold these two buttons simultaneously for 1 second either to enter or exit the menu settings.

* CVCF stands for converter mode

3-2. LED Indicators and LCD panel

There are 4 LEDs on front panel to show the UPS working status:

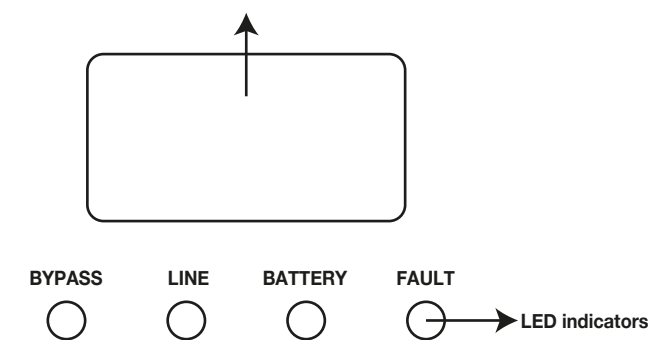

Mode \ LED	Bypass	Line	Battery	Fault
UPS startup	●	●	●	●
No Output	○	○	○	○
Bypass mode	●	○	○	○
AC mode	○	●	○	○
Battery mode	○	○	●	○
CVCF mode	○	●	○	○
Battery Test	●	●	●	○
ECO mode	●	●	○	○
Fault	○	○	○	●

Note: ● means LED is illuminated ○ means LED is not illuminated

LCD panel:

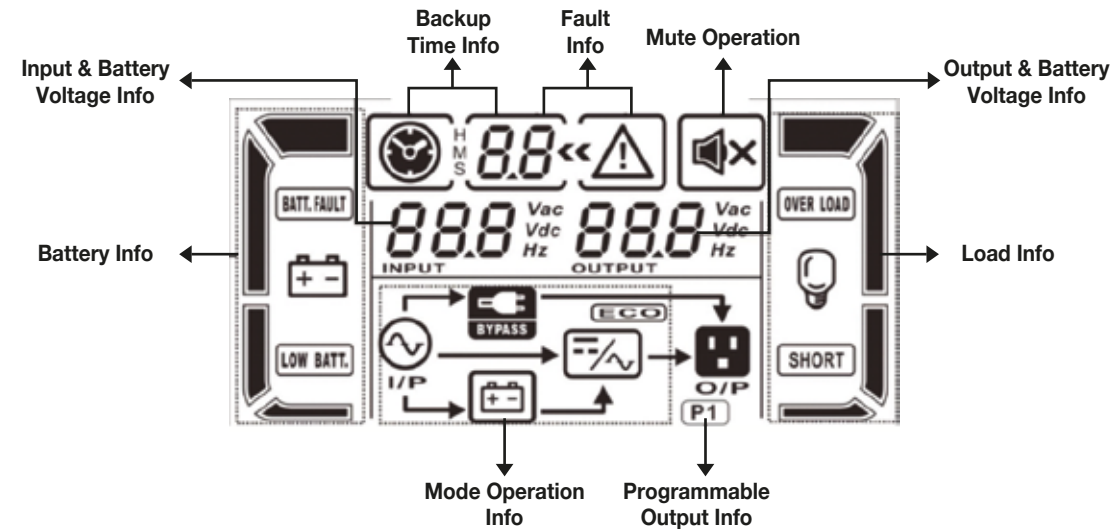

Display	Function
Backup time information	
	Provides a digital indication of the battery discharge time. H: hours M: minutes S: seconds
Fault information	
	Indicates that a warning or fault has occurred.
	Displays the fault codes, listed in detail in the sections below
Mute operation	
	Indicates that the UPS alarm has been disabled.
Output and battery voltage information	
	Provides an indication of the output voltage, frequency or battery voltage. VAC: output voltage VDC: battery voltage Hz: frequency
Load information	
	Indicates the load level at 0-25%, 26-50%, 51-75%, and 76-100%
	Indicates the load or the output is short-circuited.
	Overload indication.
Mode operation information	
	Indicates that the UPS is connected to the mains.
	Indicates the battery is in working status.
	Indicates the bypass circuit is in working status.
	Indicates the ECO mode is enabled.
	Indicates the inverter circuit is working.
	Indicates the output connector is working properly.

Battery information	
	Indicates the battery is charged at 0-25%, 26-50%, 51-75%, and 76-100% of its capacity.
	Indicates the battery is not connected.
	Low battery and low voltage indicator.
Input and battery voltage information	
	Indicates the input voltage or frequency, or battery voltage. VAC: input voltage VDC: battery voltage Hz: input frequency

3-3. Audible alarm

Description	Buzzer status	Muted
UPS status		
Bypass mode	Beeps once every 2 minutes	Yes
Battery mode	Beeps once every 4 seconds	
Fault mode	Beeps continuously	
Warning		
Overload	Beeps twice every second	Yes
Others	Beeps once every second	
Fault		
All	Beeps continuously	Yes

3-4. Single UPS Operation

1. Turn on the UPS with utility power (On grid/ AC mode)

- 1) After making sure that the power supply connection is correct, set the input breaker to the “ON” position first. At this point, the fan will start running while the UPS supplies power to the load via the bypass. The UPS is now operating in Bypass mode.
Note: When the UPS is in Bypass mode, the output voltage will directly power the load from utility after you have switched on the input breaker. In Bypass Mode, the load is not protected by the UPS. To protect your load devices, you should turn on the UPS as explained below.
- 2) Press and hold the **ON** button for 0.5 second to power on the UPS. The buzzer will beep once.
- 3) After a few seconds, the UPS will enter into the AC mode. In case of abnormal utility power, the UPS will transfer to battery mode operation to provide uninterrupted power to the outlets.
Note: In battery mode, the UPS will shut down automatically when the remaining charge is low. Once the utility power is restored, the UPS will restart automatically in AC mode.

2. Turn on the UPS without utility power (Battery mode)

- 1) Press and hold the ON button for 0.5 second to power on the UPS. The buzzer will beep once.
- 2) After a few seconds, the UPS will be turned on and begin operating on “off-grid” or Battery mode.

3. Connecting devices to the UPS

After the UPS is turned on, you can connect devices to the unit.

- 1) Turn on the UPS first and then start switching “on” one load at a time, only after all of them have been plugged into the unit. The total load level will be displayed on the LCD panel.
- 2) Should you need to connect inductive loads, such as a monitor or a laser printer to the UPS, the start-up power should be used for calculating the capacity of the UPS, as energy consumption increases during initial power on.

- 3) If the UPS is overloaded, the buzzer will beep twice every second.
- 4) In the event of an overload, all unnecessary loads must be removed one by one, to lower the total loads connected to the UPS to less than 80% of its nominal power capacity to prevent overload condition.
- 5) If the overload time exceeds the time specified in AC mode, the UPS will automatically transfer to Bypass mode. After the overload is removed, the UPS will return to AC mode. If the overload time exceeds the time specified in Battery mode, the UPS will transfer to fault status. At this time, if bypass is enabled, the UPS will supply power to the loads using the bypass mode. If the bypass function is disabled or the input power is not within the bypass acceptable range, the output power will be cut off immediately.

4. Charging the batteries

- 1) Once the UPS is connected to utility power, the unit will charge the batteries automatically, except when the USP is running in Battery mode or while the battery self-test is in progress.
- 2) It is recommended to charge the batteries at least 10 hours before use to ensure proper backup time.
- 3) Make sure battery number setting on the control board is consistent with the actual connection.

5. Battery mode operation

- 1) When the UPS is in Battery mode, the buzzer will beep according to the battery capacity.
 - a. If the battery capacity is more than 25%, the buzzer will beep once every 4 seconds.
 - b. If the battery voltage drops to the alarm triggering level, the buzzer will beep once every second to indicate that the battery has reached its lowest capacity, and that the UPS will soon shut down automatically. Shutting down non-critical loads at this point will prolong the backup time. If the programmable timer function is enabled, the UPS will shut off programmable output terminals automatically.

Note: There is the risk of data loss or load failure if battery runtime is exceeded.

- 2) To silence the buzzer sound in Battery mode, press the Mute button.
- 3) The backup time vary depending upon environment conditions and load types.
- 4) When the backup time is set at 16.5 hours (LCD panel default value), the UPS will shut down automatically to protect the battery after the discharging period of 16.5 hours is completed. This battery discharge protection can be enabled or disabled using the LCD panel control.

6. Testing the batteries

- 1) To check the battery status when the UPS is running in AC mode/CVCF mode/ECO mode, press the Test button to initiate the self-diagnostic tool.
- 2) To maintain the system reliability, the UPS will perform an automatic battery self-test on a periodic basis. The default setting for the battery self-test is once per week.
- 3) Battery self-test interval can also be set through the monitoring software.
- 4) When the UPS is in battery self-test mode, the LCD Display and buzzer indication will be the same as in battery mode, with the exception that the battery LED will appear blinking in this case.

7. Turn off the UPS with utility power in AC mode

- 1) Turn off the inverter of the UPS by pressing the **OFF** button for at least 0.5 second. The buzzer will beep once and the UPS will go into Bypass mode.

Note 1: If the UPS has been set to enable the bypass output, it will bypass voltage from utility power to the output terminal even though the UPS (inverter) has been turned off.

Note 2: After turning off the UPS, please beware that the UPS is operating in Bypass mode and there is a risk of power loss for connected devices.
- 2) In Bypass mode, output voltage of the UPS is still present. In order to shut off the output voltage, switch off the input breaker to the UPS. A few seconds later, there will be no display shown on the LCD panel while the UPS is now completely turned off.

8. Turn off the UPS without utility power supply in Battery mode

- 1) Turn off the UPS by pressing the **OFF** button for at least 0.5 second. The buzzer will beep once.
- 2) The UPS power will shut off output and there will be no indication showing on the display panel.

9. Muting the buzzer

- 1) To silence the buzzer, press the Mute button for at least 0.5 second. If you press it again, the buzzer will be enabled.
- 2) Some warning alarms cannot be muted unless the error that triggered them is fixed.

10. Operation in warning status

- 1) When the Fault LED flashes and the buzzer beeps once every second, it means that the UPS is experiencing operation issues. Fault codes are available via the LCD Panel. Refer to the troubleshooting table for additional details.
- 2) Some warning alarms cannot be muted unless the error that triggered them is fixed.

11. Operation in fault mode

- 1) When the Fault LED illuminates and the buzzer beeps continuously, it means that there is a fatal error in the UPS. Fault Codes are available via the LCD Panel. Refer to the Troubleshooting table for additional details.
- 2) Check the loads, wiring, ventilation, utility, battery and so on when a fault occurs. Do not try to turn on the UPS again before solving the problems. If the issues persist, contact the dealer or service personnel immediately.
- 3) In case of emergency, disconnect the UPS from the utility, external battery, and output immediately to avoid danger.

12. Changing battery numbers

- 1) This operation should only be performed by trained and qualified technicians.
- 2) Turn off the UPS. If the load cannot be shut down, remove the cover from the maintenance bypass switch on the rear panel of the unit, and slide the maintenance switch to the **BPS** position.
- 3) Switch off the input breaker.
- 4) Remove the UPS cover. Disconnect the battery wire and modify the jumper on the control board to set the battery numbers.

Battery number in series	JP1				
	pin1 & pin2	pin3 & pin4	pin5 & pin6	pin7 & pin8	pin9 & pin10
16	X	X	1	0	0
17	X	X	0	1	1
18	X	X	0	1	0
19	X	X	0	0	1
20	X	X	0	0	0

Note: 0 = no jumper; 1 = connect with jumper; X = the pins are for other functions.

- 5) Modify the battery pack to match the setting number in control panel.
- 6) Then, modify charger voltage according to the table below to match the setting number on the control board. There are 5 jumpers on the charger board. Please refer to the below table to modify charger voltage.

Battery number in series	Charge voltage (V)	JP01	JP02	JP03	JP04	JP05
16	218	0	0	0	1	0
17	232	0	0	1	0	0
18	245	0	1	0	0	0
19	259	1	0	0	0	0
20	273	0	0	0	0	0

Note: 0 = no jumper; 1 = connect with jumper.

- 7) After executing the previous steps, replace the UPS cover. Switch on the input breaker and the UPS will enter into the Bypass mode. If the UPS is in maintenance Bypass mode, turn the maintenance switch to the **UPS** position before turning on the system.

13. Changing charging current

- 1) This operation should only be performed by trained and qualified technicians.
- 2) Turn off the UPS. If the load couldn't be cut off, you should remove the cover of maintenance bypass switch on the rear panel and turn the maintenance switch to the **BPS** position first.
- 3) Switch off the input breaker.
- 4) Remove the cabinet cover, and disconnect battery wire. Then modify the jumpers on the charger board to set the charging current (refer to table below). Be careful that the maximum setting should not exceed the charging current acceptable for the battery.

Charge current (A)	JP06	JP07	JP08
1A	0	0	1
2A	0	1	0
3A	1	0	0
4A	0	0	0

Note: 0 = no jumper; 1 = connect with jumper

3.5 Parallel operation

UPS installation for parallel systems

If the UPS is only available for single operation, you may skip this section to the next.

1. Please follow the instructions to make sure the UPS systems are correctly wired for parallel operation. Refer to the illustration below:

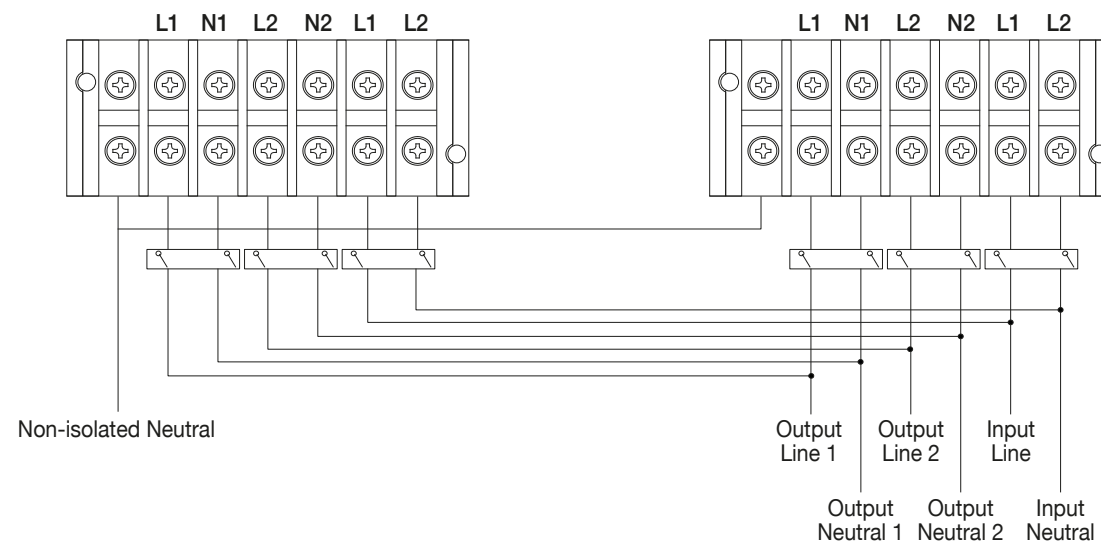

Important Connect the **Non-isolated neutral** between each UPS. (This is the electric reference point for the transformer)

1. Failure to connect the **Non-isolated neutral** between each UPS may permanently damage the units.
2. Connect the output of each UPS to an output breaker.
3. Connect all output breakers to a main breaker. The latter is the one that will be connected to the loads.
4. If using external power banks, each UPS must be connected to its own power bank. In the event a single power bank is used for all the UPS units, it will cause permanent damage to the equipment.
5. Connect both parallel cables between each UPS, the communications cable (DB-25) and the load balancing cable, as illustrated below:

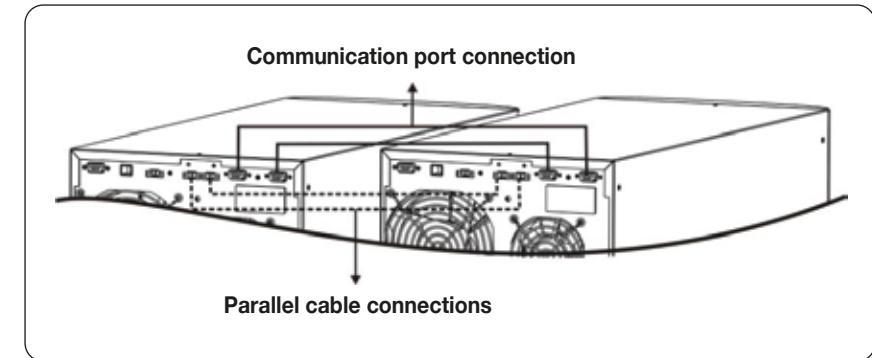

Once the above connections are completed, verify that the following conditions are met:

1. Verify that the input voltage is the same for all UPS units (208, 220, 230 or 240V)
2. Turn on the UPS and the battery breaker located on the back panel of the UPS.
3. If the configuration is successful, the following screen will be displayed in all UPS units.

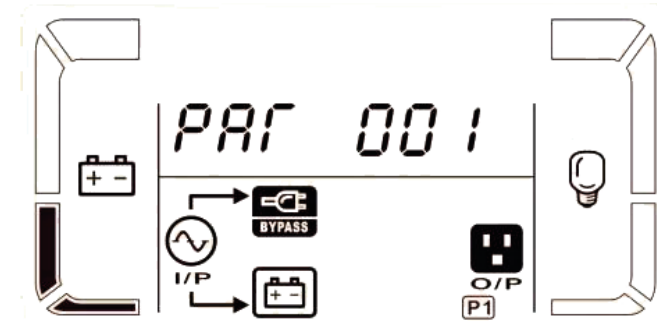

4. Verify the output voltage in Bypass mode using one enabled output breaker.
5. Next, turn the other output breaker on making sure that output is the same output in every UPS. The output difference among all UPS units must not exceed 1V.
6. Once you have checked all the above, turn OFF all the UPS units and output breakers in order for this configuration to take effect.
7. Finally, power on the UPS units to begin operation in Parallel mode.

3-6. Abbreviations on the LCD display

Abbreviation	Display content	Meaning
ENA	ENR	Enable
DIS	diS	Disable
ATO	ARtO	Auto
BAT	bARt	Battery
NCF	nCF	Normal mode (not CVCF mode)
CF	CF	CVCF mode
SUB	SUB	Subtract

Abbreviation	Display content	Meaning
ADD	<i>Add</i>	Add
ON	<i>ON</i>	On
OFF	<i>OFF</i>	Off
FBD	<i>Fbd</i>	Not allowed
OPN	<i>OPN</i>	Allow
RES	<i>RES</i>	Reserved
PAR	<i>PAR</i>	Parallel

3-7. UPS parameter settings

Three parameters need to be configured in order to set up the UPS. Refer to the following diagram.

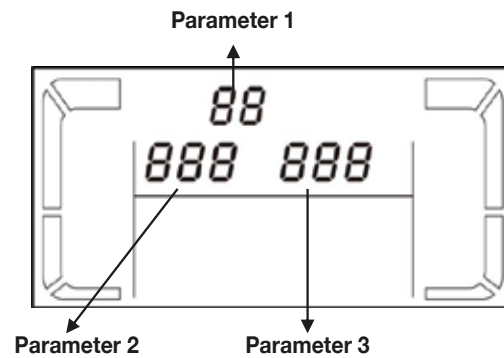

Parameter 1: it is used for the different configuration options. There are 15 programs to set up. Refer to the table below.
Parameter 2 and parameter 3: they represent the setting options or values of each program.

List of the 15 programs for parameter 1:

Code	Description	Bypass	AC	ECO	CVCF	Battery	Battery test
01	Output voltage	Y					
02	Output frequency	Y					
03	Voltage range for bypass	Y					
04	Frequency range for bypass	Y					
05	ECO mode enable/disable	Y					
06	Voltage range for ECO mode	Y					
07	ECO mode frequency range setting	Y					
08	Bypass mode setting	Y	Y				
09	Battery backup time setting	Y	Y	Y	Y	Y	Y
10	Reserved		Reserved for future use				
11	Reserved		Reserved for future use				
12	Hot standby function enable/disable	Y	Y	Y	Y	Y	Y
13	Battery voltage adjustment	Y	Y	Y	Y	Y	Y
14	Charger voltage adjustment	Y	Y	Y	Y	Y	Y
15	Output voltage adjustment		Y		Y	Y	

*Y means that this program can be set in this mode

Note: All parameter settings will be saved only when UPS shuts down normally with internal or external battery connection. (Normal UPS shutdown means turning off input breaker in bypass/no output mode).

01: Output voltage settings

Interface	Setting
	<p>Parameter 3: Output voltage You may choose the following output voltage in parameter 3: For 100/110/115/120/127VAC models, you may choose the following output voltage:</p> <p>208: The output voltage is 208VAC 220: The output voltage is 220VAC 230: The output voltage is 230VAC 240: The output voltage is 240VAC 100: The output voltage is 100VAC 110: The output voltage is 110VAC 115: The output voltage is 115VAC 120: The output voltage is 120VAC 127: The output voltage is 127VAC</p>

02: Output frequency settings

Interface	Setting
<p>60 Hz, CVCF mode</p>	<p>Parameter 2: Output frequency To set the output frequency, choose any of the following three options in parameter 2: 50.0Hz: The output frequency is set to 50.0Hz. 60.0Hz: The output frequency is set to 60.0Hz. ATO: When selected, the output frequency will be set according to the latest normal utility frequency. If it ranges from 46Hz to 54Hz, the output frequency will be 50.0Hz. If it ranges from 56Hz to 64Hz, the output frequency will be set at 60.0Hz. ATO is the default setting.</p> <p>Parameter 3: Frequency mode Enables you to set the output frequency in either CVCF mode or no CVCF mode. You may choose any of the following two options in parameter 3: CF: Sets the UPS in the CVCF mode. If selected, the output frequency will be fixed at 50Hz or 60Hz according to the setting in parameter 2. The input frequency could range from 46Hz to 64Hz. NCF: Sets the UPS to normal mode (not CVCF mode). If selected, the output frequency will synchronize with the input frequency within 46~54 Hz at 50Hz or within 56~64 Hz at 60Hz according to the setting defined in parameter 2. If 50Hz is selected in parameter 2, the UPS will transfer to battery mode provided the input frequency does not fall within 46~54Hz range. If 60Hz is selected in parameter 2, the UPS will transfer to battery mode provided the input frequency does not fall within the 56~64Hz range. *If ATO is selected in Parameter 2, Parameter 3 will show the current frequency</p>
<p>50 Hz, Normal mode</p>	
<p>ATO</p>	

Note: If the UPS is set to CVCF mode, the bypass function will be disabled automatically. But when a single UPS without parallel function is powered on with utility power and before the UPS finishes the startup, there will be a few seconds of voltage pulse (same as the input voltage) on the bypass output. If you need to remove the pulse on this mode to better protect your load, you could contact the dealer for help. This situation will not happen in UPS units working on parallel mode.

03: Voltage range for bypass

Interface	Setting
	<p>Parameter 2: Sets the acceptable low voltage for bypass operation. Setting ranges from 110V to 209V, with a default value of 110V.</p> <p>Parameter 3: Sets the acceptable high voltage for bypass operation. Setting ranges from 231V to 276V, with a default value of 264V.</p>

04: Frequency range for bypass

Interface	Setting
	<p>Parameter 2: Sets the acceptable low frequency for bypass operation. 50Hz system: Setting ranges from 46.0Hz to 49.0Hz. 60Hz system: Setting ranges from 56.0Hz to 59.0Hz. The default value is 46.0Hz/56.0Hz.</p> <p>Parameter 3: Sets the acceptable high frequency for bypass operation. 50Hz: Setting ranges from 51.0Hz to 54.0 Hz. 60Hz: Setting ranges from 61.0Hz to 64.0Hz. The default value is 54.0Hz/64.0Hz.</p>

05: ECO mode enable/disable

Interface	Setting
	<p>Parameter 3: Enables or disables the ECO feature. You may choose between the following two options:</p> <p>DIS: disables the ECO feature</p> <p>ENA: enables the ECO feature</p> <p>When the ECO feature is disabled, the voltage and frequency range can still be set for this mode, however, such parameters will take effect only if the ECO function has been enabled.</p>

06: Voltage range for ECO mode

Interface	Setting
	<p>Parameter 2: Sets the low voltage point in ECO mode. This setting ranges from 5% to 10% of the nominal voltage.</p> <p>Parameter 3: Sets the high voltage point in ECO mode. This setting ranges from 5% to 10% of the nominal voltage.</p>

07: Frequency range for ECO mode

Interface	Setting
	<p>Parameter 2: Sets low frequency point for ECO mode. 50Hz system: Ranges from 46.0Hz to 48.0Hz. 60Hz system: Ranges from 56.0Hz to 58.0Hz. The default value is 48.0Hz/58.0Hz.</p> <p>Parameter 3: Sets the high frequency point for ECO mode. 50Hz: Ranges from 52.0Hz to 54.0 Hz. 60Hz: Ranges from 62.0Hz to 64.0Hz. The default value is 52.0Hz/62.0Hz.</p>

08: Bypass mode setting

Interface	Setting
	<p>Parameter 2: OPN: Bypass allowed. When selected, the UPS will operate in Bypass mode depending on the enable/disable bypass setting. FBD: Bypass not allowed. When selected, the UPS will not be able to operate in Bypass mode under any circumstances.</p> <p>Parameter 3: ENA: Bypass enabled. When selected, it means that the Bypass mode is activated. DIS: Bypass disabled. When selected, the automatic bypass may be used, but manual bypass is never allowed. Manual bypass allows users to manually operate the UPS in Bypass mode. For example, by pressing the OFF button in AC mode, it will cause the unit to start running in Bypass mode.</p>

09: Battery backup time setting

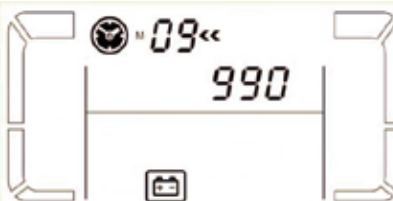
Interface	Setting
	<p>Parameter 3: 000~999: Sets the maximum backup time from 0min to 999min. UPS will shut down to protect battery after backup time expires. The default value is 990min.</p> <p>DIS: When battery discharge protection is disabled, the backup time will depend on battery capacity. "DIS" is the default value.</p>

10: Reserved

Interface	Setting
	Reserved

11: Reserved

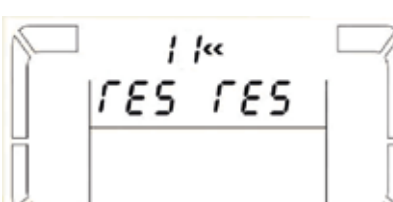
Interface	Setting
	Reserved

12: Hot standby function enable/disable

Interface	Setting
	<p>Parameter 2: HS.H: Enables or disables the Hot standby function. You may choose one of the following two options in Parameter 3: YES: Hot standby function is enabled. It means that the current UPS is set to hot standby, and it will restart once electricity is reestablished, even without having a battery connected. NO: Hot standby function is disabled. The UPS is operating in normal mode and cannot restart without battery.</p>

13: Battery voltage adjustment

Interface	Setting
	<p>Parameter 2: Select Add or Sub function to adjust battery voltage to its actual reading. Parameter 3: the voltage ranges from 0V to 5.7V, the default value is 0V.</p>

14: Charger voltage adjustment

Interface	Setting
	<p>Parameter 2: You may choose Add or Sub to adjust the charger voltage Parameter 3: The voltage ranges from 0V to 9.9V, the default value is 0V. NOTE: *Before making any voltage adjustment, be sure to disconnect all batteries first to get the accurate charger voltage. *We strongly suggest using the default value (0). Any modification should match battery specifications.</p>

15: Output voltage adjustment



Interface	Setting
	<p>Parameter 2: You may choose Add or Sub to adjust the output voltage. Parameter 3: The voltage ranges from 0V to 6.4V, the default value is 0V.</p>

3-8. Operating mode/Status description

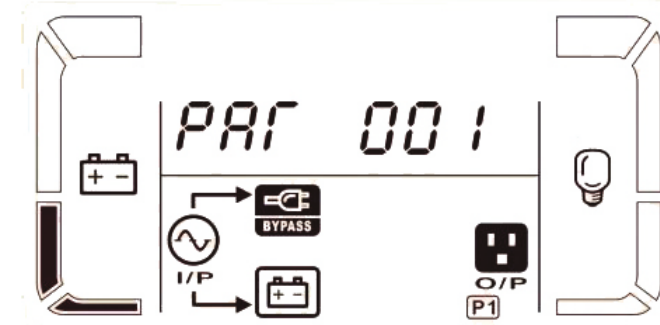

When parallel UPS systems are successfully set up, an additional screen with “PAR” in parameter 2 will be displayed and assigned a number in parameter 3, as shown below. The master UPS will be assigned “001” as default, while the slave UPSs will be identified as either “002” or “003”. The assigned numbers may be changed dynamically during operation.

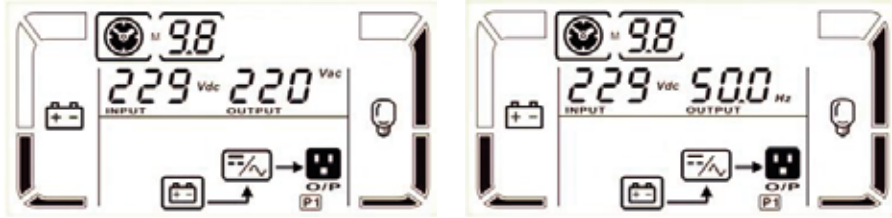
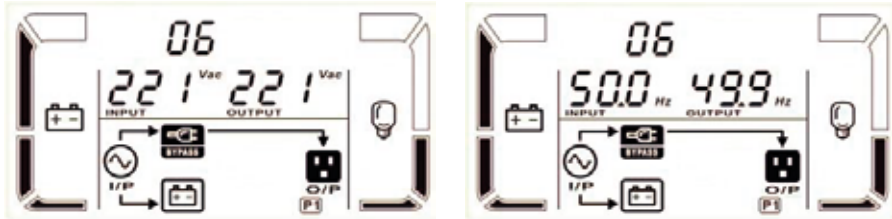
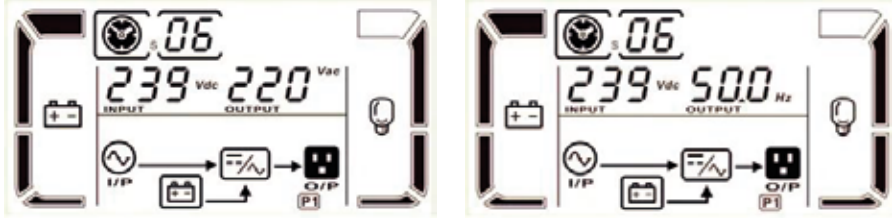









Operating mode/status		Description
AC mode	Description	When the input voltage is within an acceptable range, the UPS will provide pure and stable AC power to the output. The UPS will also charge the battery in AC mode.
	LCD display	
ECO mode	Description	When the input voltage is within the voltage regulation range and ECO mode is enabled, the UPS will bypass voltage to output for energy saving.
	LCD display	
CVCF mode	Description	When input frequency is within 46 and 64Hz, the UPS can be set at a constant output frequency of 50Hz or 60Hz. The UPS will still charge the battery under this mode.
	LCD display	

Operating mode/status		
Battery mode	Description	When the input voltage exceeds the acceptable range or during a power failure, the UPS will start supplying power from the battery while the alarm will beep every 4 seconds.
	LCD display	
Bypass mode	Description	When input voltage is within the acceptable range and bypass is enabled, turn off the UPS in order to transfer the unit to Bypass mode. The alarm beeps every two minutes in this case.
	LCD display	
Battery test	Description	When UPS is in AC mode or CVCF mode, press and hold the Test key for 0.5 second. The UPS will beep once and start performing the "Battery test". The line between I/P and inverter icons blinks while the diagnostics is in progress. This operation is used to check the battery status.
	LCD display	
Fault status	Description	In the event of abnormal operation, the LCD panel will display the corresponding fault message on the LCD panel.
	LCD display	

3-9. Fault codes

Fault event	Fault code	Icon	Fault event	Fault code	Icon
Bus start failure	01	None	Battery SCR short circuited	21	None
Bus over	02	None	Inverter relay short circuited	24	None
Bus under	03	None	Charger short circuited	2a	None
Bus unbalance	04	None	Parallel communication fault	31	None
Inverter soft start failure	11	None	Parallel output current unbalance	36	None
High inverter voltage	12	None	Over temperature	41	None
Low inverter voltage	13	None	CPU communication failure	42	None
Inverter output short circuited	14		Overload	43	
Negative power fault	1A	None	Battery turn-on failure	6A	None
Inverter over current	60	None	PFC current failure in battery mode	6B	None
Inverter waveform abnormal	63	None	Bus voltage changes too fast	6C	None

3-10. Warning indicators









Warning	Icon (blinking)	Alarm
Battery low		Beeps once every second
Overload		Beeps twice every second
Battery unconnected		Beeps once every second
Over charge		Beeps once every second
EPO enable		Beeps once every second
Fan failure/Over temperature		Beeps once every second
Charger failure		Beeps once every second
I/P fuse broken		Beeps once every second
Overload 3 times in 30min		Beeps once every second

3-11. Warning codes

Warning code	Warning event	Warning code	Warning event
01	Battery is not connected	10	L1 IP fuse is blown
07	Over charge	21	Line issues are different in a parallel system
08	Low battery	22	Bypass issues are different in parallel system
09	Overload	33	Locked in bypass after an overload is detected 3 times in 30 minutes
0A	Fan failure	3A	Cover of maintenance switch is open
0B	EPO enable	3D	Bypass is unstable
0D	Over temperature	3E	Boot loader is missing
0E	Charger failure		

4. Troubleshooting guide

If the UPS system does not operate correctly, use the table below to troubleshoot the problem.

Symptom	Possible cause	Solution
Even though the mains supply is normal, and there are no status indicators or alarms.	The AC input power is not properly connected.	Check to make sure the power cord is firmly connected to an AC wall socket.
The  icon and the warning code EP blink on the LCD display and the alarm starts beeping once every second.	EPO function is enabled.	Set the circuit in closed position to disable EPO function.
The  and  icons blink on the LCD display and the alarm starts beeping once every second.	The external or internal battery is incorrectly connected.	Check if all batteries are properly connected.
The  and  icons blink on the LCD display and the alarm beeps twice every second.	UPS is overloaded.	Remove excess loads from the UPS output.
	UPS is overloaded. Devices connected to the UPS are fed directly by the electrical network via the bypass.	Remove excess loads from the UPS output.
	After repetitive overloads, the UPS is locked in the Bypass mode. Connected devices are fed directly by the mains.	Remove excess loads from UPS output first. Then shut down the UPS and restart it.
Fault code 43 becomes illuminated along with the  icon on the LCD display, and the alarm starts beeping continuously.	The UPS shuts down automatically upon detecting an overload on the UPS output.	Remove excess loads from the UPS output and restart the unit once again.
Fault code 14 becomes illuminated along with the  icon on the LCD display, and the alarm starts beeping continuously.	The UPS shuts down automatically upon detecting a short circuit on the UPS output.	Check the output wiring and if the connected devices are short-circuited.
Fault codes 01, 02, 03, 04, 11, 12, 13, 14,1A, 21, 24, 35, 36, 41, 42 or 43 become illuminated on the LCD display, and the alarm starts beeping continuously.	A UPS internal fault has occurred. There are two possible causes: 1. Power is continued to be supplied to the load, but is done directly from the AC grid via a bypass. 2. Power is no longer supplied to the load.	Please contact the dealer or service center.
Battery backup time is shorter than its nominal value.	Batteries are not fully charged.	Charge the batteries for at least 7 hours and then check their capacity. If the problem still persists, consult your dealer.
	Defective batteries.	Contact your dealer for a replacement.
The  and  icons become illuminated on the LCD display, and the alarm starts beeping once every second.	Fan is either locked, has stopped working, or the UPS temperature is too high.	Check fans and notify dealer.











5. Storage and maintenance

5-1. Storage

Charge the UPS for at least 7 hours before storing the unit. Cover the UPS, and place it upright in a cool, dry location. During storage, recharge the battery in accordance with the following table:

Storage temperature	Recharge frequency	Runtime
-25°C - 40°C	Every 3 months	1-2 hours
40°C - 45°C	Every 2 months	1-2 hours

5-2. Maintenance

-  The UPS system operates with hazardous voltages. Repairs may be carried out only by qualified maintenance personnel.
-  Even after the unit is disconnected from the mains, components inside the UPS system are still connected to the battery packs which are potentially dangerous.
-  Before carrying out any kind of service and/or maintenance, disconnect the batteries and verify that no current is present and no hazardous voltage exists in the terminals of high capability capacitor such as BUS-capacitors.
-  Servicing of batteries should be performed or supervised by personnel with knowledge of batteries and the required precautions. Keep unauthorized personnel away from batteries.
-  Verify that no voltage between the battery terminals and the ground is present before maintenance or repair. In this product, the battery circuit is not isolated from the input voltage. Hazardous voltages may occur between the battery terminals and the ground.
-  A battery can present a risk of electric shock and high short circuit current. The following precaution should be observed when working on batteries:
 - Remove watches, rings or other metal objects.
 - Use tools with insulated handles.
-  Replace batteries with the same type and number of units.
-  Do not attempt to dispose of batteries by burning them. This could cause battery explosion. The batteries must be properly deposited according to local regulation.
-  Do not open or destroy batteries. Released electrolyte is highly poisonous and harmful to the skin and eyes.
-  Replace the fuse only with the same type and amperage in order to avoid fire hazards.
-  Do not disassemble the UPS system.

6. Technical specifications

MPN	FDC106K	FDC110K
General		
Capacity	6000VA/6000W	10000VA/10000W
Topology	Double conversion	
Input		
Nominal voltage	110-300VAC	
Voltage range (low line transfer)	176VAC / 140VAC / 110VAC ± 3% (based on load percentage 100%-80% / 80%-60% / 60%-0%)	
Voltage range (low line comeback)	Low-line transfer voltage + 10V	
Voltage range (high line transfer)	300VAC ± 3%	
Voltage range (high line comeback)	High line transfer voltage - 10V	
Frequency	46-54Hz at 50Hz system / 56-64Hz at 60Hz system	
Power factor	≥0.99 at 100% load	
Total harmonic distortion (THD)	<4% at 100% load / <6% at 50% load	
AC plug style	Hard wired	
Output		
Nominal voltage	104/110/115/120VAC or 208/220/230/240VAC	
AC voltage regulation (battery mode)	± 1%	
Frequency (synchronized range)	46-54Hz at 50Hz system / 56-64Hz at 60Hz system	
Frequency (battery mode)	50Hz ± 0.1Hz or 60Hz ± 0.1Hz	
Power factor	1	
Efficiency (AC mode)	> 90%	
Efficiency (battery mode)	> 88%	
Overload	AC mode: 100%-110%: 10min / 110%-130%: 1min / >130%: 1sec Battery mode: 100%-110%: 30sec / 110%-130%: 10sec / >130%: 1sec	
Transfer time (line to battery)	0ms	
Transfer time (inverter to bypass)	0ms	
Crest ratio	3:1 (max)	
Harmonic distortion	≤2% THD (linear load) / ≤6% THD (non-linear load)	
Waveform	Pure sine wave	
Total outlets	Terminal block	
Battery		
Battery type and quantity	12V / 9Ah (20)	
Recharge time	9 hours to 90% capacity	
Charging current	1A ± 10% (max)	
Charging voltage	273VDC ± 1%	
Communications		
LCD display	Graphical LCD with blue backlight	
Visual indicators	Status LEDs	
Audible	Battery mode: Sounds every 4 seconds Low battery: Sounds every second Overload: Sounds every 0.5 second Fault: Continuous sound	
Communication ports	SNMP, RS-232, USB	
Power management software	Included	
Environment		
Operating temperature	32°F-104°F	
Storage temperature	UPS: -5°F-140°F Battery: 32°F-95°F	
Relative humidity	20-90% non-condensing	
Operating altitude	<1000m Every 100m above 1000m decreases output power 1% up to 4000m	
Audible noise	<58dB at 1 meter	
Physical appearance		
Product Dimensions	23.3x9.9x32.5in	
Product Weight	256lb	313lb
Additional information		
Warranty	Two years *	

* Derate capacity to 50% of capacity in CVCF mode and to 90% when the output voltage is adjusted to 208VAC.

** If the UPS is installed or used in a place where the altitude is above than 1000m, the output power must be derated one percent per 100m.

*** Product specifications are subject to change without further notice.

forza[®]
POWER TECHNOLOGIES

www.forzaups.com